



Genesis Double Adjustable Shock Assembly and Repair

General Operating Description

The Genesis Adjustable Shock is adjusted by moving one or both of two bypassing sliding valves. These valves slide longitudinally inside the hollow rod at the piston end. As the valves move up and down they occlude or open holes in the side of the rod that connect to passages in the interior of the piston. The valves are connected to the adjuster mechanism through the center of the shock rod by the means of adjuster rods that are threaded at one end that screws into the valve and have rack gear teeth on the other end that engage a pinion gear in the adjuster body.

In the adjuster body the pinion gear meshes with a worm gear onto which a knob is attached. Rotating the knob turns the pinion which moves the rack and, via the rod, the valve up or down.

Internal to the piston is a passage that connects the holes in the rod to ports on the rebound and compression sides of the piston. A check ball in this passage moves with the fluid flow to open or close the port. Fluid that flows through this path bypasses the piston disc valve stack and as a result changes the force-velocity response of the shock absorber.

Basic Shock Disassembly for Repair

Disassembly:

1. Wash shock to remove loose dirt.
2. Depress Schrader valve to release all gas pressure.
3. Remove Schrader valve (33).
4. Install floating piston (30) set tool.
5. Put shock in vise and remove seal screw from bottom closure cap assembly (32).
6. Holding reservoir (28) with reservoir wrench, loosen bottom closure cap assembly (32) then completely unscrew.
7. Install oil drip cup and pull out piston and rod assembly.

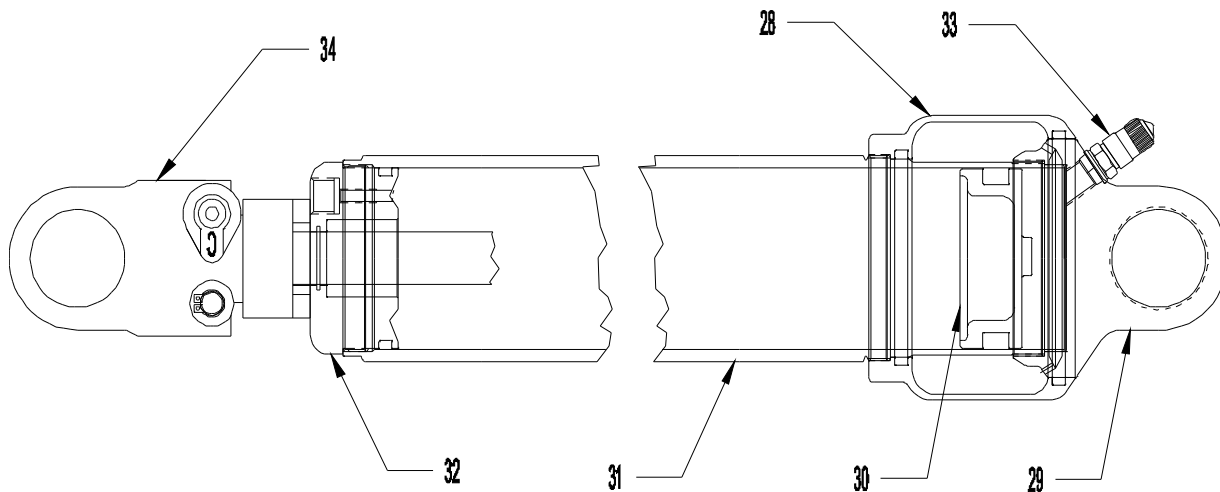

Double Adjustable Parts

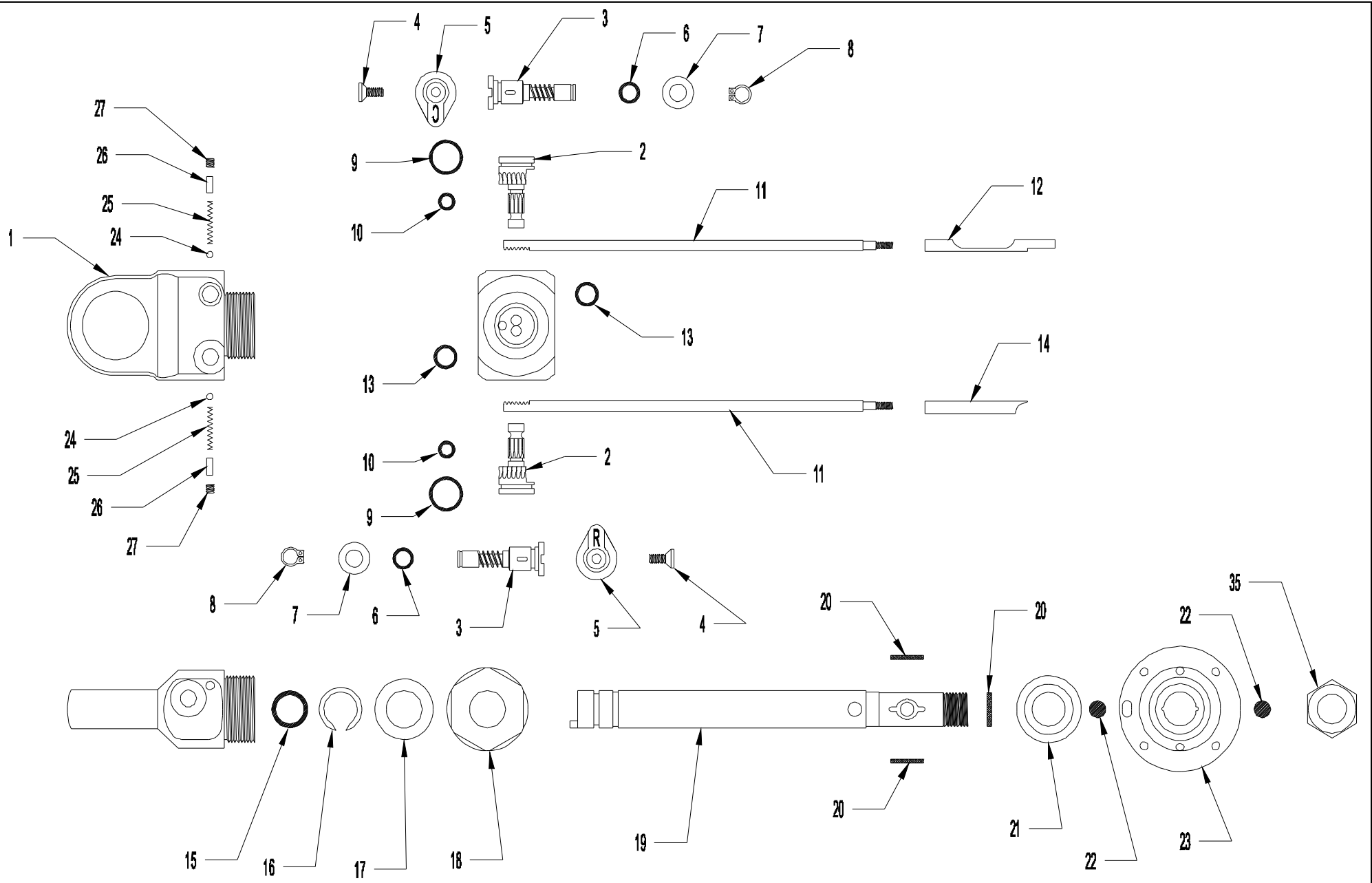

Drawings Legend

Feature Number	Part Description	Part Number
1	Adjuster Body	8830
2	Pinion Gear	8880
3	Worm Gear	8885
4	Adjuster Knob Screw	2210-632FHCS SS
5	Adjuster Knob	8887-R or C
6	O-ring (optional)	2002-M6x1
7	Washer	2008-25
8	Worm Gear Retaining Clip	2050-25S
9	O-ring	2002-M11x1
10	O-ring	2002-M4.5x1
11	Pushrod	8860-(stroke)
12	Compression Slider Valve	8866
13	O-ring (optional)	2002-M7x1
14	Rebound Slider Valve	8865
15	O-ring	2002-M11x1.5
16	Rod Retaining Clip	8840
17	Adjuster Body Retaining Washer	8845
18	Adjuster Body Retaining Nut	8835
19	Adjustable Shock Rod	8854-(stroke)
20	Dowel Pin	2030-06500
21	Adjustable Rod Stop Washer	8850
22	Piston Check Ball	2010-250N
23	Adjustable Piston	8810-(several)
24	Detent Ball	2010-094S
25	Detent Spring	2020-0088012-0620
26	Detent Spacer Pin	2210-094x250
27	Socket Head Set Screw	2210-6-32x125
28	Reservoir	5300
29	Top Cap	5200
30	Floating Piston	5700
31	Shock Body	5100-(stroke)
32	Bottom Closure Cap Assembly	A5800
33	Schrader Valve	5250
34	Double Adjuster Assembly	A8300
35	1/2-20 Nyloc Jam Nut	5510
36	O-ring	2002-129
37	Wear Band	5150

Replacing a Damaged Adjustable Shock Rod

The most common repairable damage to a shock is a bent shock rod. With the adjustable shock, the severity of bend will dictate the degree of repair.

Do not attempt to rotate the double adjuster assembly (34) in relation to the rod. All parts are indexed with pins and most parts will be ruined if rotated.

Secure the piston and rod assembly by clamping adjuster body (1) in soft jaws in a vise. Remove the adjuster body retaining nut (18) from the adjuster body. If you can pull the adjuster body with its attached push rods (11) and slider valves (12 and 14) from the adjustable shock rod (19), then the repair will only require a new rod as it is unlikely that the push rods are bent. If the shock rod is so severely bent that you cannot pull the push rods out, then they and the sliders and the shock rod will have to be replaced. Further, if the push rods cannot be pulled out, you will have to "wind" the double adjuster assembly away from the rods. This is done by turning the adjuster knobs (5) counterclockwise alternating between rebound and compression until the double adjuster assembly comes free.

Next, clamp the adjustable shock rod (19) in soft jaws in a vise. Remove the 1/2 – 20 nyloc jam nut (35) from the piston end of the rod.

Do not attempt to rotate the adjustable piston (23) in relation to the rod. All parts are indexed with pins and most parts will be ruined if rotated.

Remove the spacer washers and valve discs from the rod. **Maintain all parts in order of removal so re-assembly will be correct.** Slide the piston from the rod. This may have to be tapped with a plastic hammer. Watch for and secure the two delrin check balls (22) from the interior of the piston. Remove the three dowel pins (20), two on sides and one thru the rod. Remove the compression valve stack and spacers.

Then, loosen rod in vise and with the adjustable rod stop washer (21) resting on jaws, drive the rod out of the washer. This is a light press fit and may require some force. Slide the bottom closure cap assembly (32) and the adjuster body retaining washer (17) off the rod.

You have now salvaged all reusable parts and are ready for reassembly.

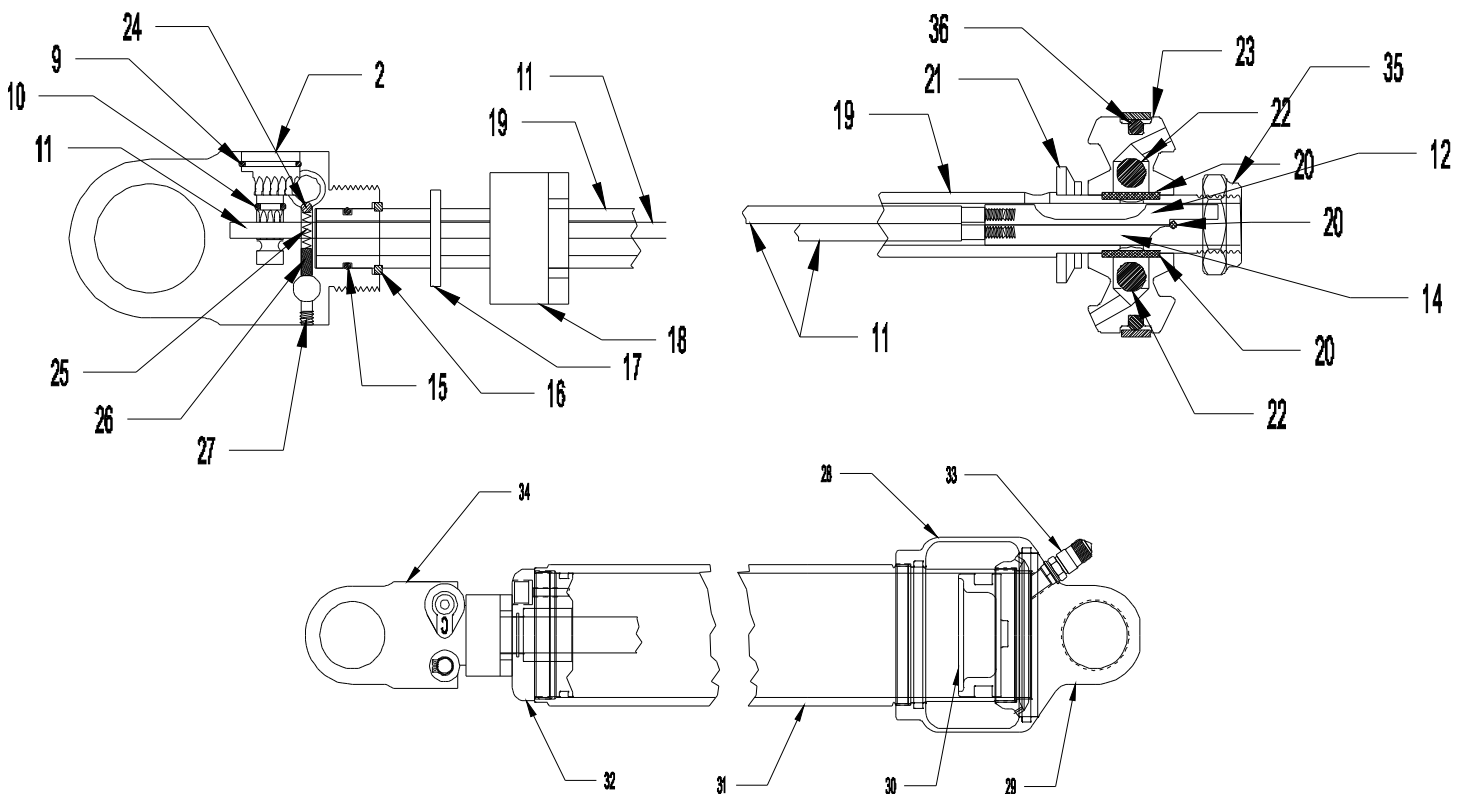

Reassembly

The new rod needs to be fitted with a new rod retaining clip (16) and a new o-ring (15). Using an external clip pliers **spread clip just enough** to slide over rod, past the o-ring groove and into clip groove. Over-spreading of clip will ruin it as it will not fit in adjuster body. Then install o-ring and lube with grease or O-lube. If the double adjuster assembly was removed with the pushrods and slider valves attached, then you are ready for reassembly. If not, go to section on rebuilding adjuster assembly.

First, wind both adjuster knobs clockwise until they stop. **This is important. Damage will occur unless this is done first.** Put one of the dowel pins (20) in the cross hole in the rod. This pin both aligns/indexes the slider valves and is the maximum stop when the adjuster knobs are turned counter clockwise after assembly.

If the adjuster knobs will not turn, then there is damage to the adjuster assembly and it must be repaired or replaced. Go to section on rebuilding adjuster assembly.

Line up the shock rod so that the compression slider (12) is on the side of rod with two large holes. Push the sliders and push rods into center of shock rod. The sliders must slide past the dowel pin at piston end and rod indexing pin must engage rod indexing pin hole in adjuster body at the same time. Do not force this fit. When all is properly seated the large hole in the side of the rod closest to threaded end will be closed by slider. This is the same side of rod with two large holes. At the same time the rod retaining clip will be seated in the recess in adjuster body.

Slide adjuster body retaining washer (17) on rod followed by adjuster body retaining nut (18). Put adjuster body in vise, coat threads with 242 Loctite, screw on nut and torque to 40 lb-ft. Reinstall bottom closure cap assembly (32) on rod followed by the adjustable rod stop washer (21). The washer is a light press fit and must be driven on until fully seated.

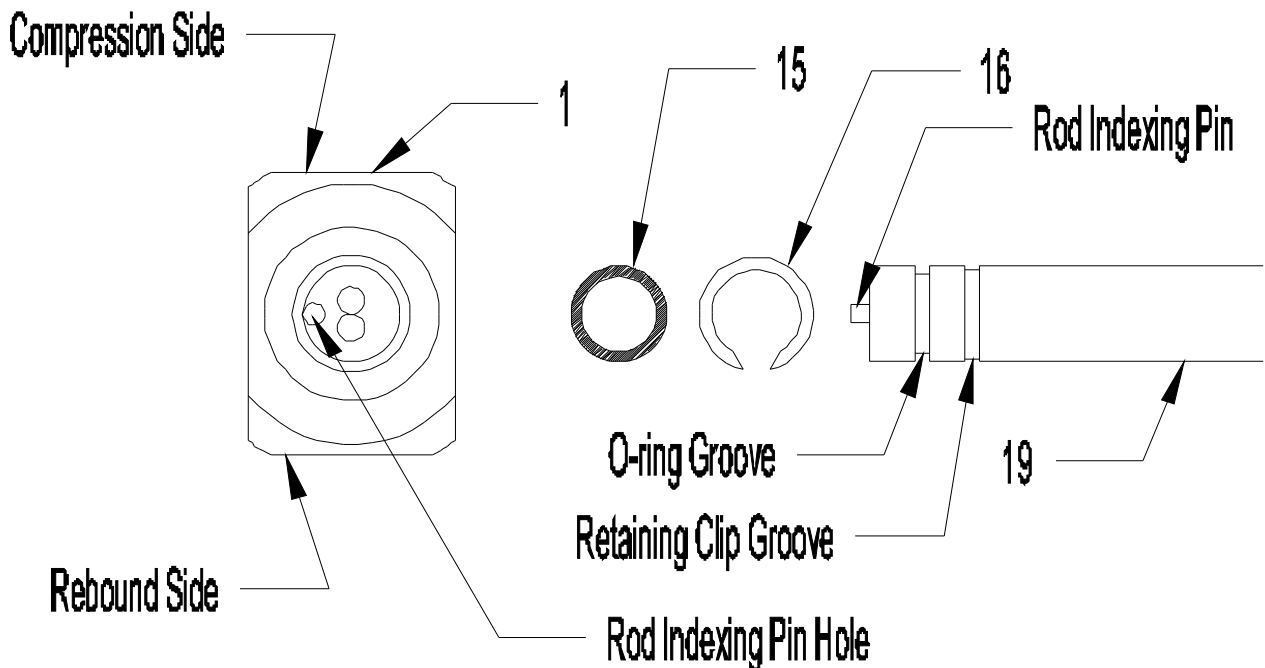

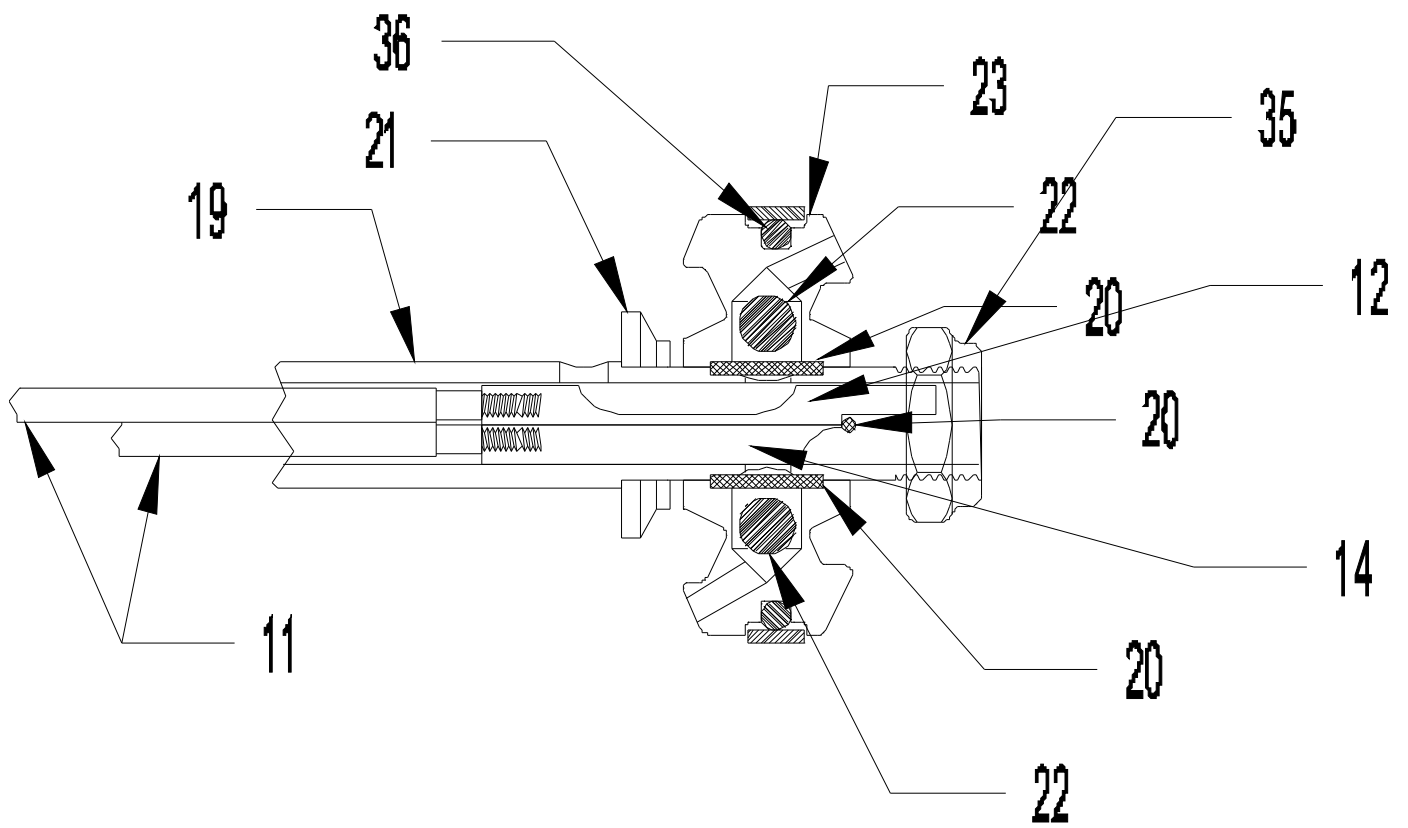

Final Assembly

1. Push in piston and rod assembly with wear band until piston is submerged in oil.
2. Strike rod with mallet lightly, until floating piston is in contact with floating piston set tool, then strike firmly to release any trapped air in assembly.
3. With rod fully extended (without piston coming out of oil), back-fill shock until oil is about $\frac{3}{4}$ " from top.
4. Push bottom closure cap assembly down until threads are engaged, then tighten cap until within $\frac{1}{8}$ " of full closure.
5. Push rod as far down as possible.
6. Re-install seal screw and tighten screw.
7. Remove oil drip cup.
8. Complete tightening of cap.
9. Remove shock from vise, remove floating piston set tool, re-install Schrader valve and gas shock to appropriate pressure.